

FAUBION SCHEMATIC DESIGN

DAG #10 AGENDA

- Welcome
- Project update
- Overview of DAG input
- Design update
- Questions

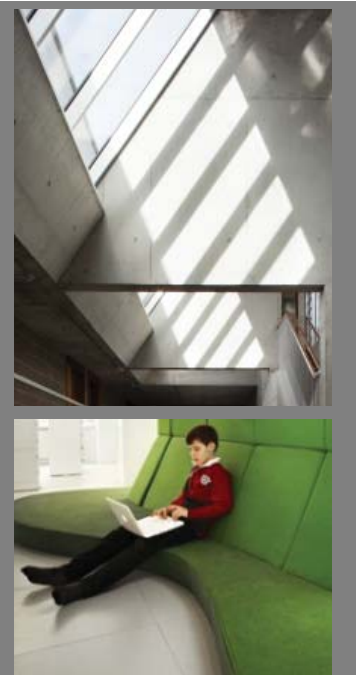
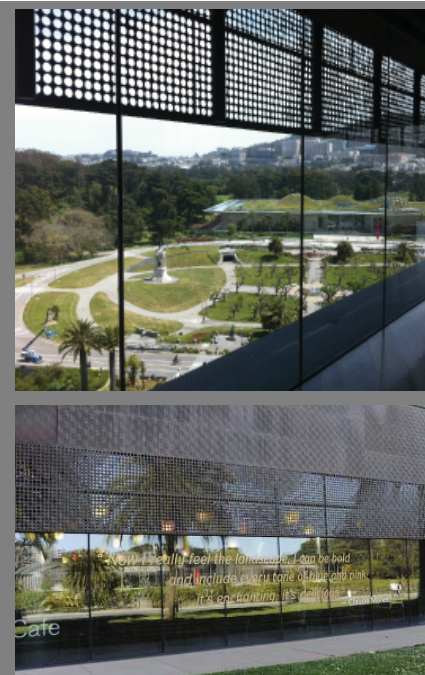

FAUBION SCHEMATIC DESIGN

100% SCHEMATIC DESIGN - December 2014

Deliverables

- Land use application
- Site plan
- Floor plans and exterior design
- Cost estimate

What have we been doing?

- Program development
- Building systems
- Exterior design
- Site plan

FEEDBACK

DAG #9

- **Play areas**

- create a side for younger kids
- put older kids closer to grass field
- provide painted games (4-square, etc)
- enhance path around field
- provide exterior storage and power

- **Exterior design**

- incorporate inspirational words, murals



SITE SCHEMATIC PLAN

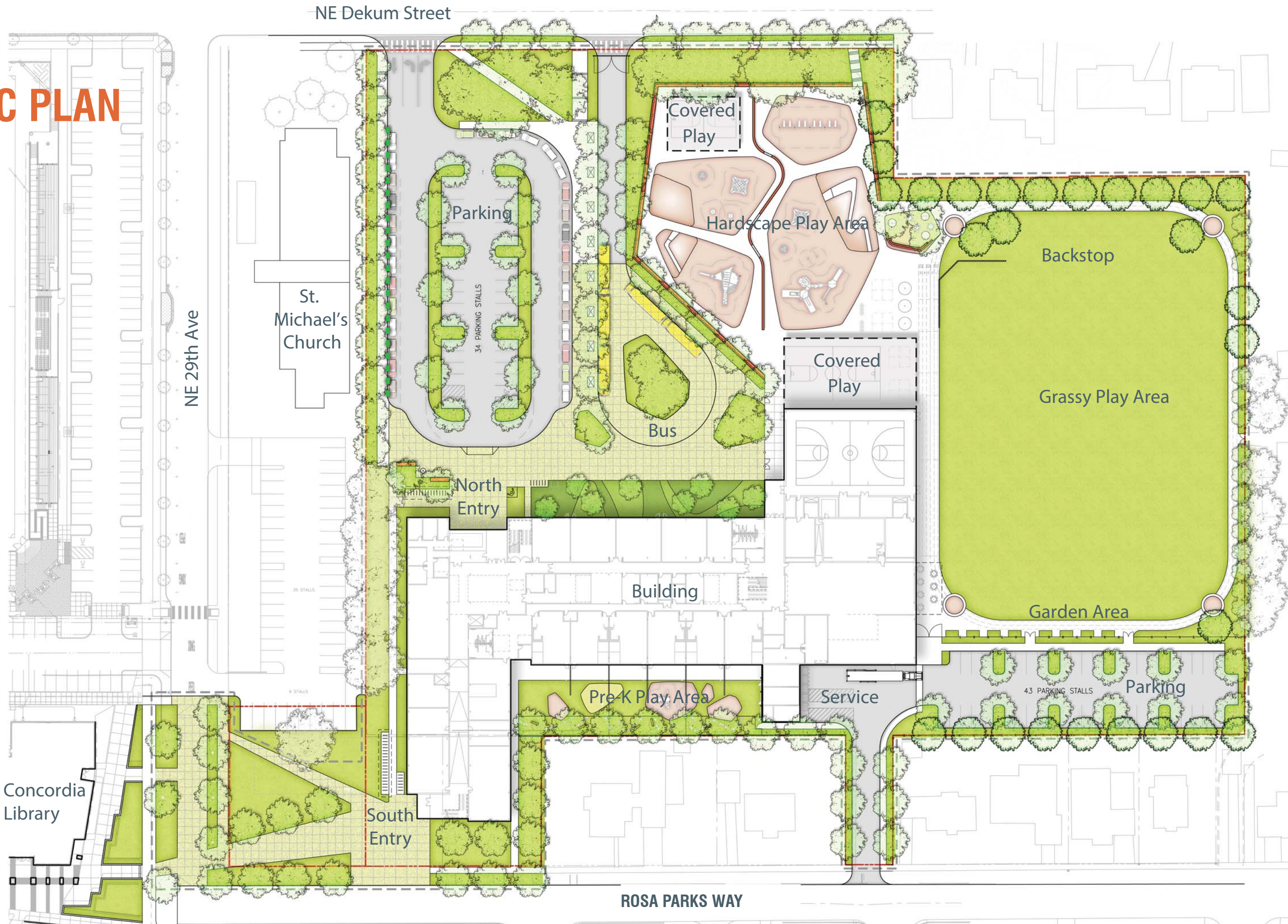

EXTERIOR DESIGN EVOLUTION

MAY 2014



SOUTH ENTRY



NORTH ENTRY

STRATEGIES

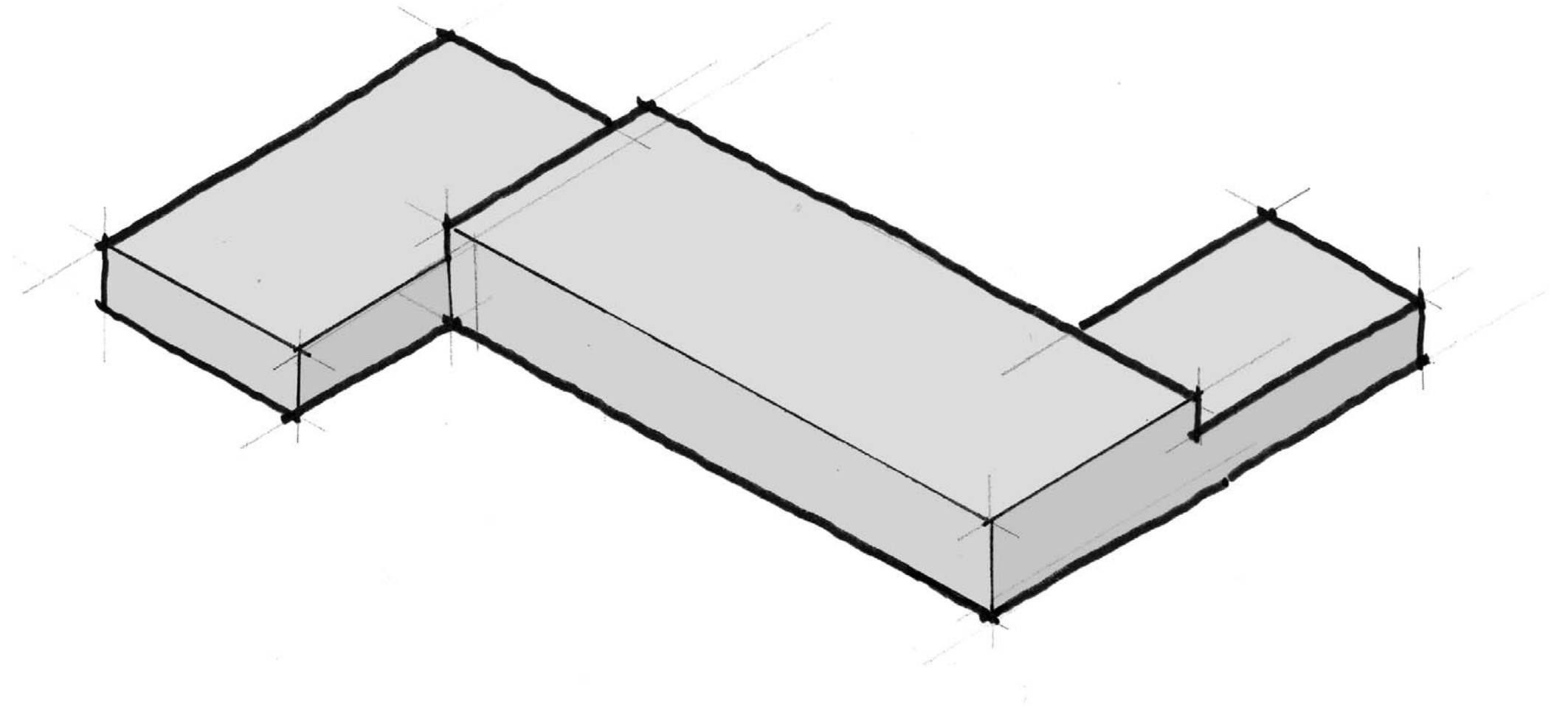

STRATEGIES

Welcoming

- Exterior spaces to gather
- Encourage interaction with school

} inflections, clear entries, porches

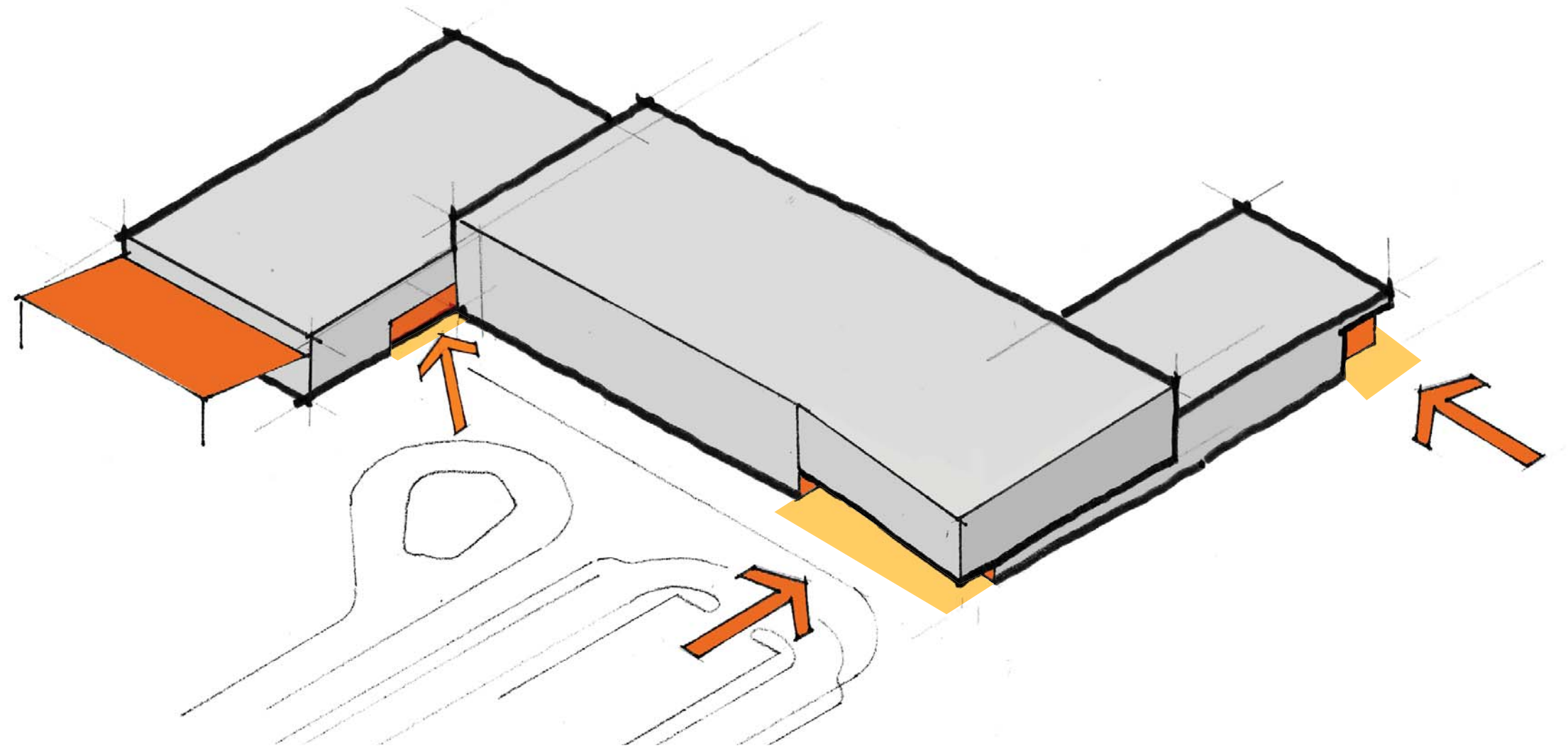

STRATEGIES

Extroverted

- Display its mission to all
- Draw people in to the collaborative core

} sense of movement, transparency, signage

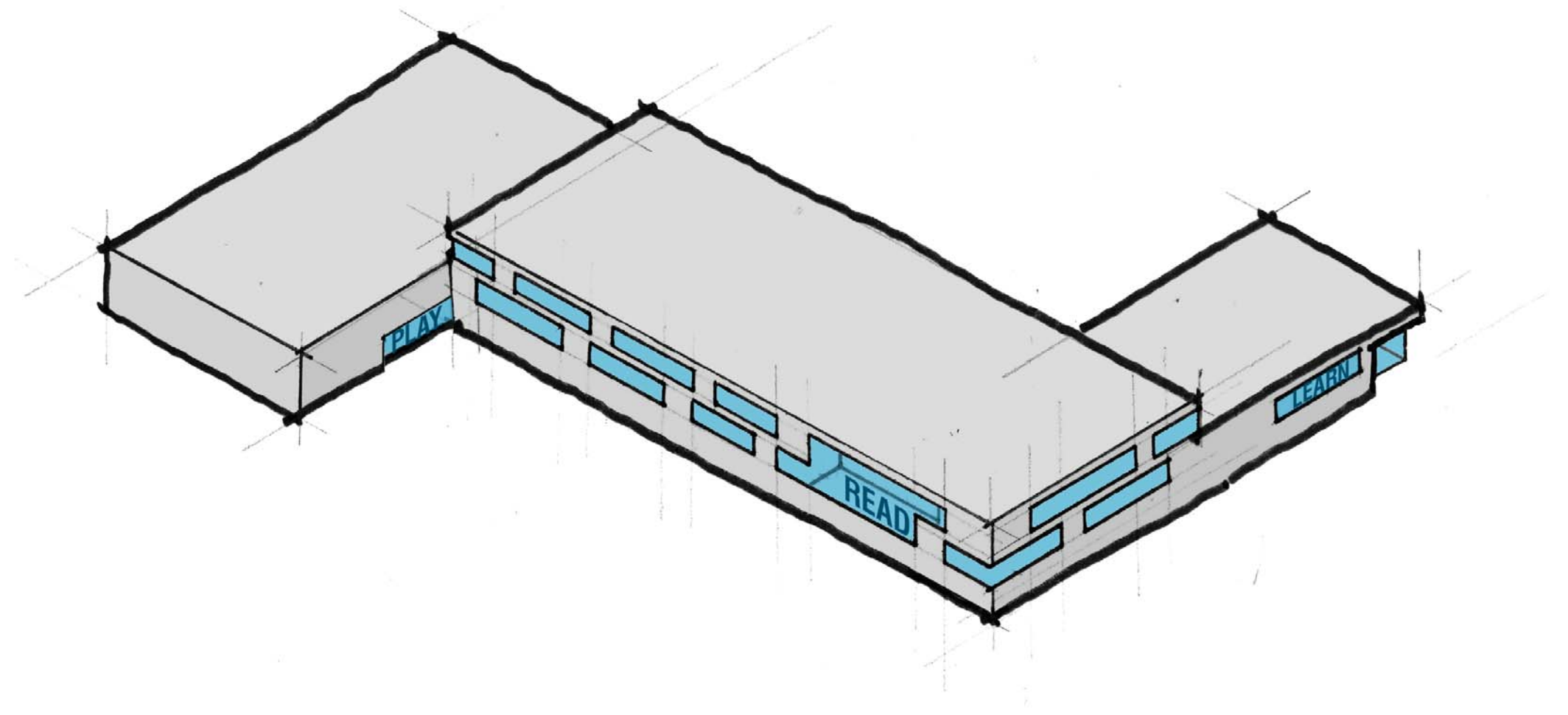

STRATEGIES

Unifying

- Connect Faubion and Concordia
- Reflect school spirit

} materials, proportions, color, display

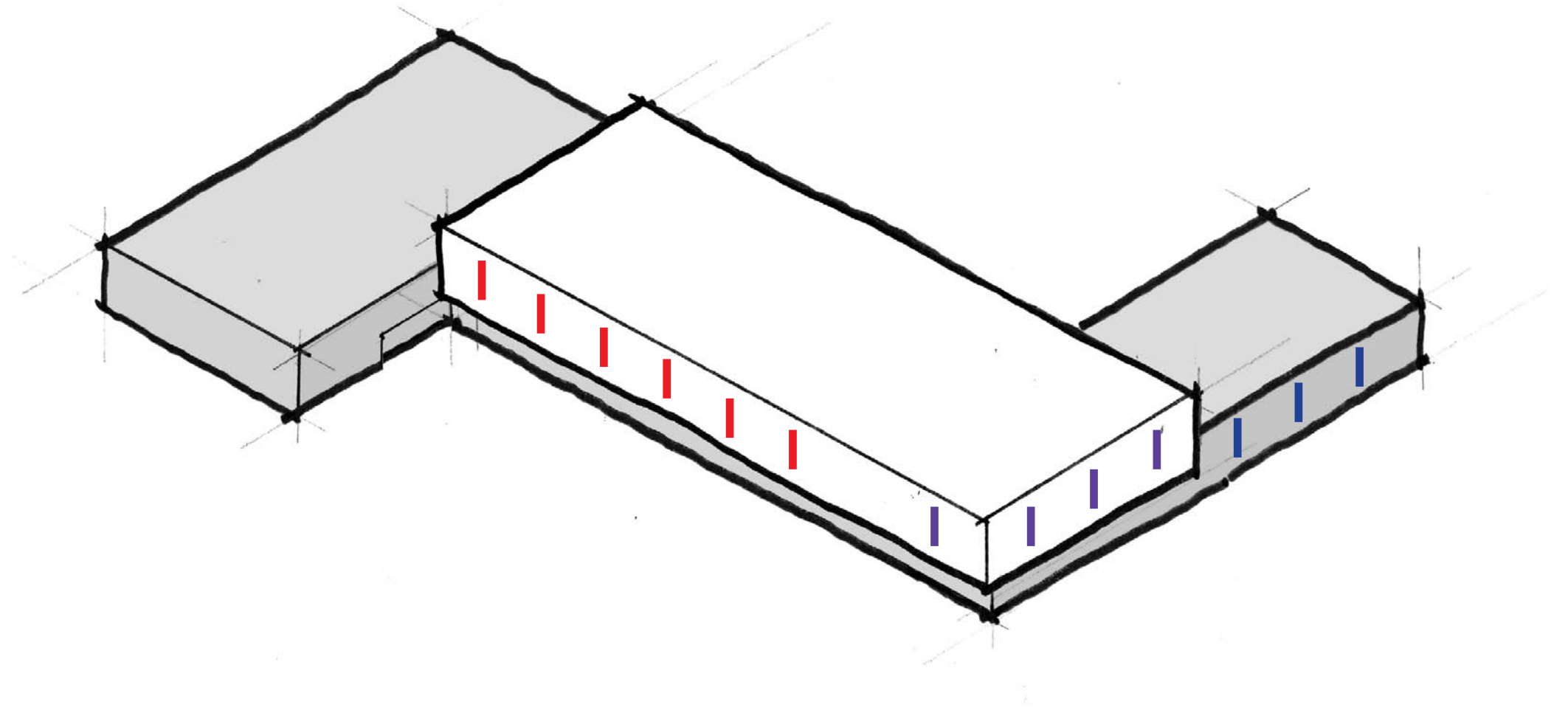

EXTERIOR MATERIALS OPTIONS



Concrete / Masonry

Metal Panel



Color Accent

EXTERIOR DESIGN

MASSING

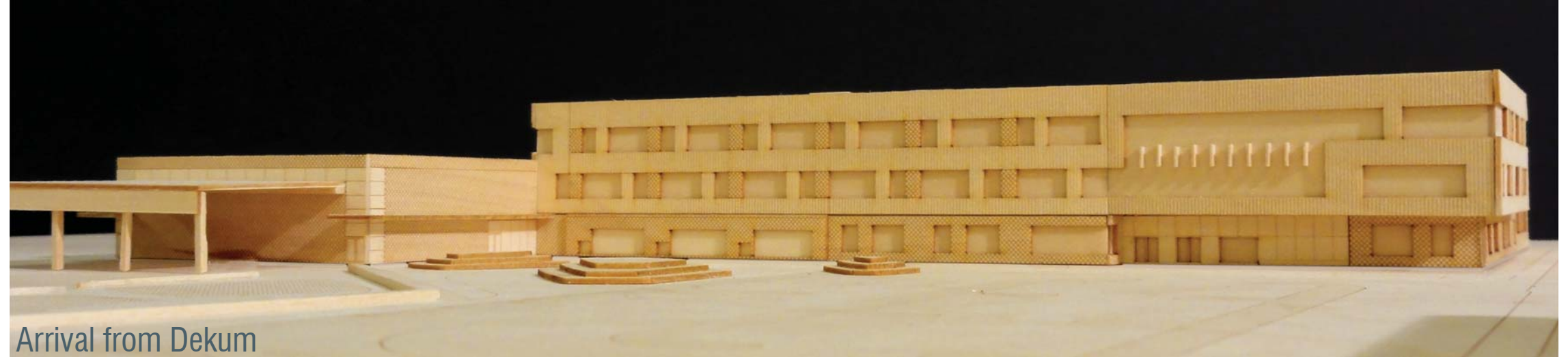

Arrival from Dekum

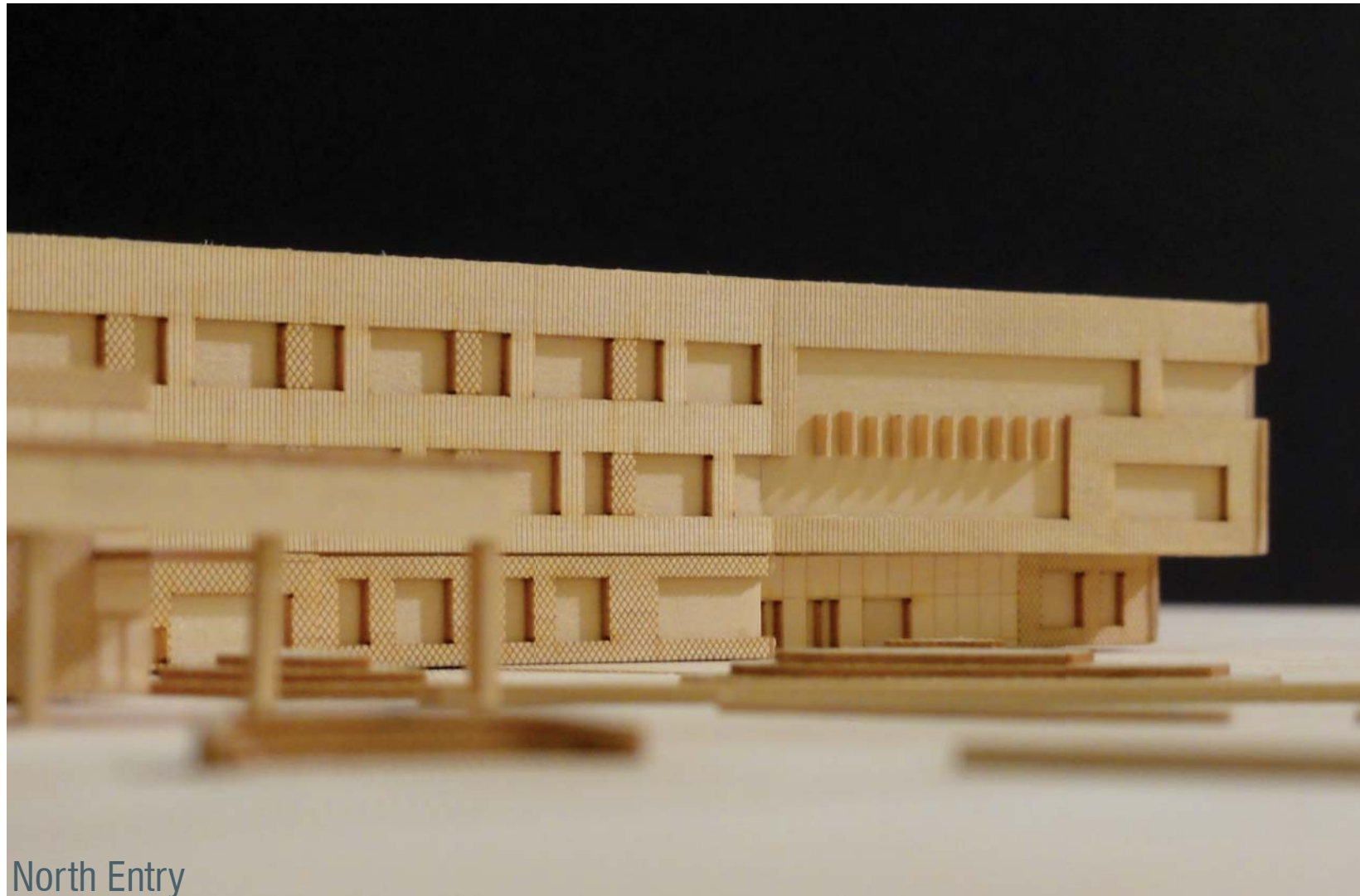

North Entry



South Entry

EXTERIOR SCALE

ENTRY



EXTERIOR SCALE

ENTRY



EXTERIOR SCALE

CLASSROOM CORE

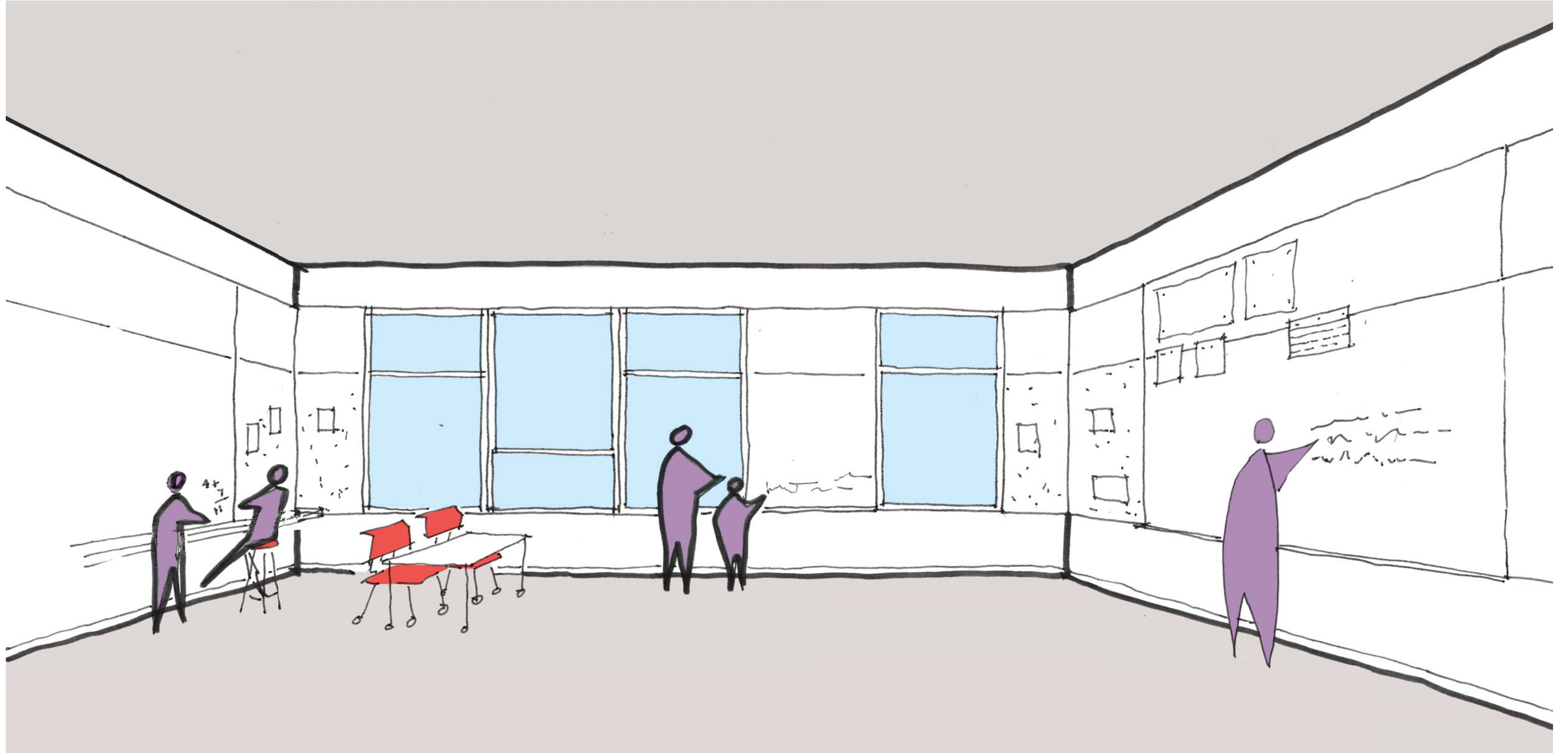

SWING SITE OVERVIEW

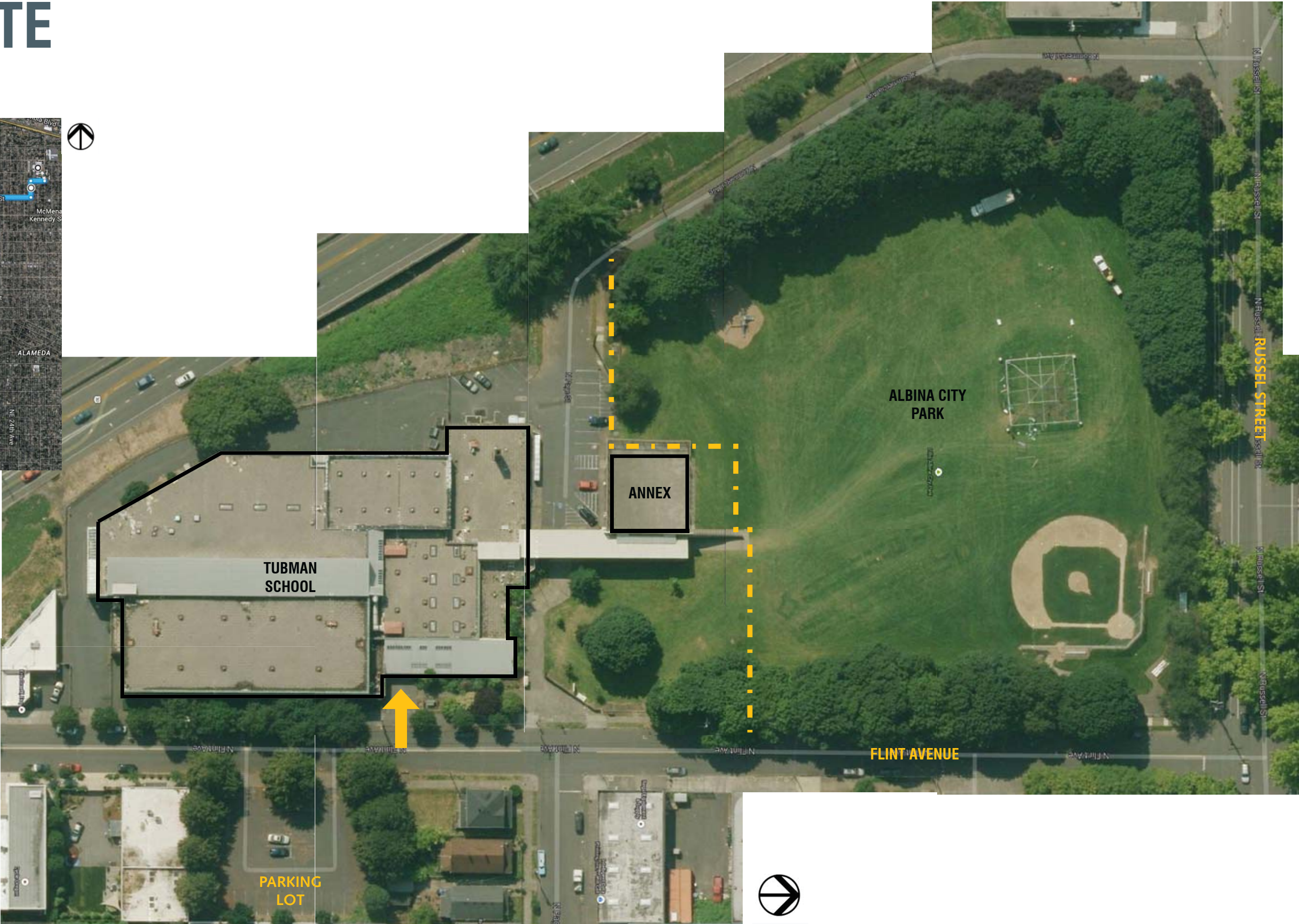
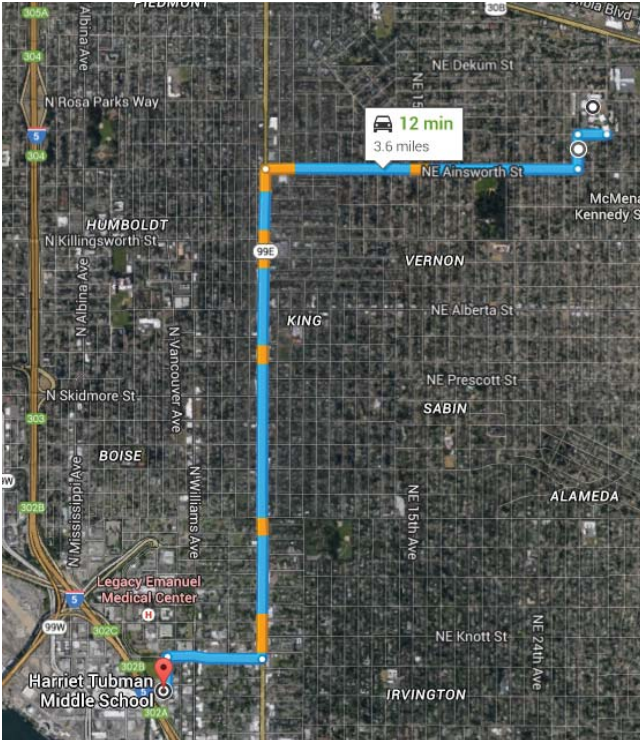

SWING SITE

DRAFT SPACE PLAN

- STEAM/Flex space
- Classrooms
- Program space
- Partner space

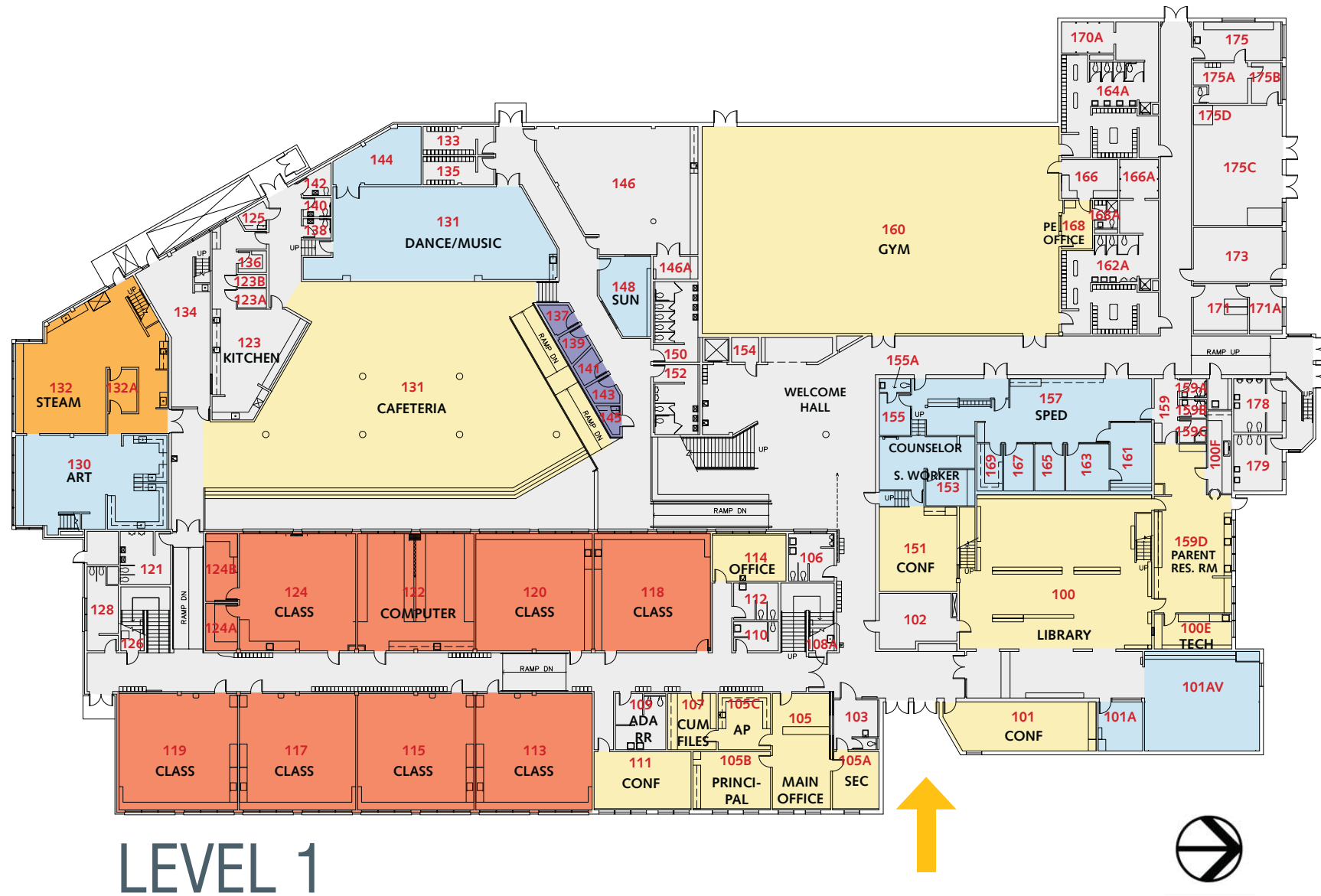
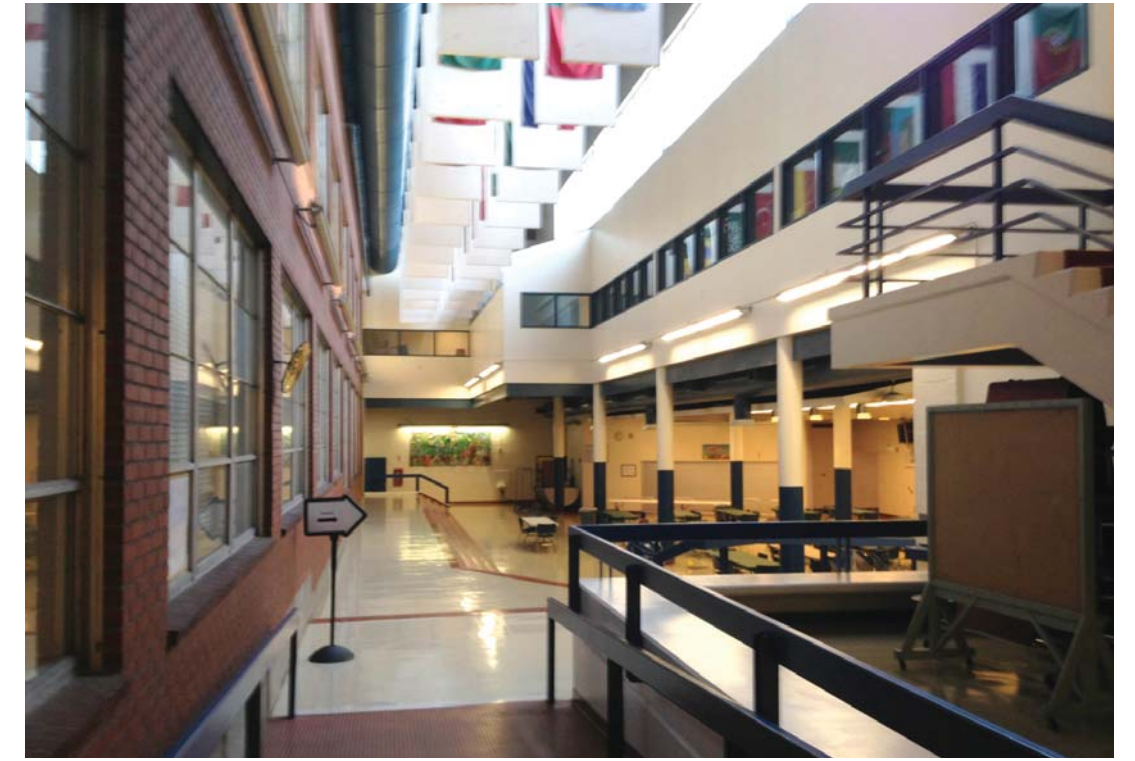

SWING SITE

PROTOTYPE OPPORTUNITIES

- Classroom
- Flex space
- Maker spaces
- Welcome hall
- College of Ed program spaces

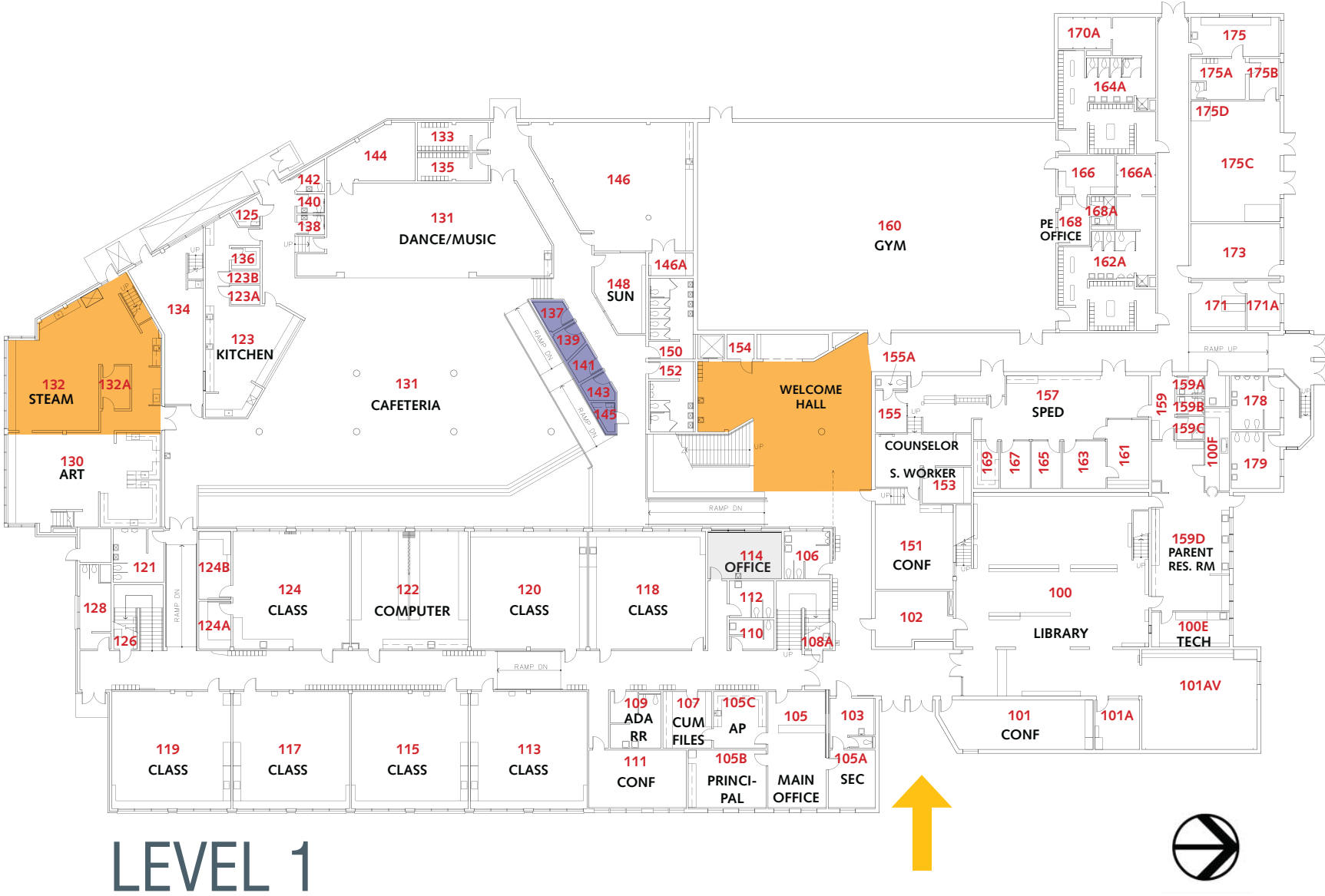

Thank you!

